

VITALink® RHW-2

 **2 Hour
Fire Rated
Power Cable**

90°C, 600 Volt
NEC Type RHW
UL Listed

Installation Guide For Type RHW-2 Fire Rated Applications

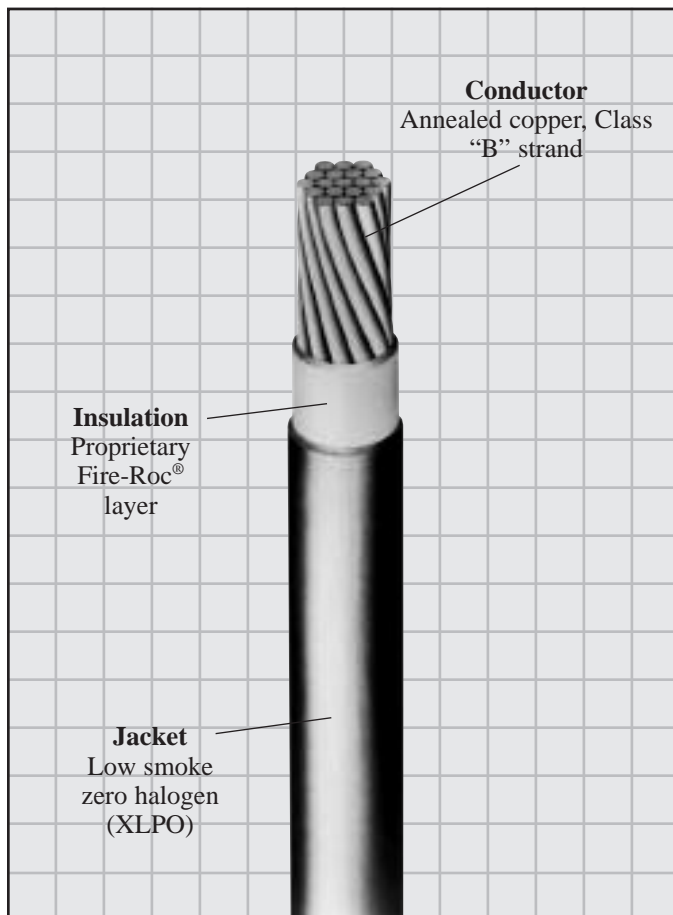

Scope

VITALink[®] RHW-2 is a unique cable which offers superior fire endurance capabilities along with the well established benefits & features associated with NEC Type RHW-2 cable designs. This cable is specifically designed to meet the circuit integrity requirements Articles 695 & 700 “Fire Pump” & “Emergency Systems” of the NEC.

Introduction

The following are abridged installation instructions on VITALink[®] RHW-2 which details the System 33 instructions and the recommended use of a junction box at electrical switch gear/equipment. Complete installation information can be found in the RSCC Installation Manual (Technical Manual 3000). The National Electrical Code as well as all applicable rules and regulations, including federal, state, local, and municipal laws should be followed.

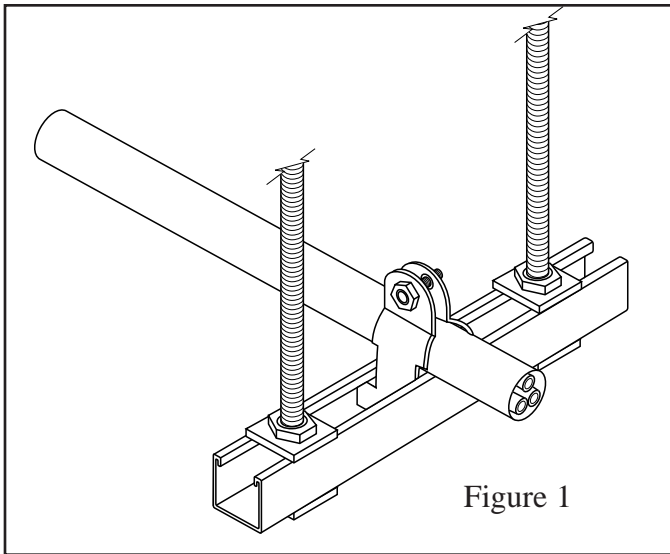

Figure 1

Electrical Circuit Protective System 33

Electrical Circuit Protective Systems consist of components and materials that are intended for installation as protection for specific electrical wiring systems, with respect to the disruption of electrical circuit integrity upon exterior fire exposure. The specifications for the protective system and its assembly are important details in the development of the ratings. Ratings apply only to the entire protective system assembly, constructed using the combination of components specified in the system. Individual components and materials are designated for use in a specific system(s) for which corresponding ratings have been developed, and are not intended to be interchanged between systems. Ratings are not assigned to individual system components or materials.

The Electrical Circuit Protective Systems must be fastened to a concrete or masonry wall or a concrete floor-ceiling assembly. The fire rating of wall or floor-ceiling assembly must be equal to or greater than the rating of the electrical circuit protective system. This is to ensure that the complete electrical circuit protective system will survive during the fire and hose stream exposure.

These protective systems are evaluated by the fire exposure and water hose stream test as described in the Outline of Investigation, "Fire Tests for Electrical Circuit Protection Systems." UL Subject UL 2196. Each design of fire resistive cable is tested per ANSI/UL 2196.

The system contains the construction details of the tested configuration. The minimum conductor size, UL Type, voltage rating, etc. are construction details that are also provided. Cables are UL Listed to a National Electrical Code Type and constructed to a UL standard for the cable (such as Type RHH/RHW-2 to UL 44).

Cables are tested as a complete system. The system includes the cable or raceway support, couplings, boxes/conduit bodies, optional splices, vertical supports, grounds, pulling lubricants, cable tray, etc. Cable or raceway supports need to hold the cable in place during the fire and hose stream. The hardware, clamps, strut, etc. are generally stated to be made of steel so that these components do not melt in the fire.

Systems that require a raceway are to be tested with the minimum raceway diameter and the minimum raceway type with their respective coupling(s). Raceways having

larger diameters are acceptable. Raceways with greater wall thickness are also acceptable. Intermediate Metal Conduit (IMC) is acceptable for use in systems where Electrical Metallic Tubing (EMT) is specified. The raceway must be connected together using the coupling type listed in the system, such as steel setscrew type for EMT or threaded types of coupling for IMC. No other coupling shall be used unless noted in the specific system.

A box, conduit body, supports (such as a grip), splice or other tested components will be noted in the system. For systems installed in a raceway, the National Electrical Code (NEC) requires not more than 360 degrees of bends without a pull point (such as conduit bodies or boxes). Conduit bodies and boxes, are acceptable, as described in the system. Since boxes are tested with a single raceway, each individual raceway shall have an independent box used for pull points or splices. If a splice is tested, it will also be listed in the system. Boxes shall be sized per the method described in the NEC.

The supports are an important part of the systems and each individual system has specific support requirements. The maximum distance between the supports is listed in the system and should not be exceeded even if an alternative raceway is used. The type of support and the distance between the steel supports is unique to that specific system and is for all sizes/types of cable and/or conduits/raceways unless otherwise noted in a specific system. Support of tray should also be the same as the raceway spacing unless otherwise noted.

The supports for both the vertical or horizontal configuration are intended to be the support to the cable/conductor. Cables installed in a vertical raceway are not supported by the raceway. The ability of cable to support the equivalent cable weight of the distance specified in Table 300.19 of the NEC (or a lesser distance), with out breaking the conductor, and compatibility/mechanical considerations of the support mechanism are evaluated in the test by simulating the weight of the vertical cable run. The vertical distance tested and the support mechanism are detailed in the system.

Compatibility of materials used in fire rated systems is also a concern. Some materials can provide carbon residue that is conductive, or conductive gasses that can cause premature failure. A dedicated raceway is the required configuration unless otherwise noted in the system (such as the option of bare ground wires, or insulated ground wires). The bare or insulated ground wire is of special manufacture to be compatible with system. RSCC Wire & Cable is the manufacturer of an allowable ground wire. As an alternative, the ground can be the same as the fire rated wire listed in the system. Use of any other ground wire violates the system fire rating. As an example, THHN ground wire shall not be used with a fire rated system unless specified in the system. Also, a standard bare ground wire may lose strength in a fire. The pulling lubricant tested with the system is so noted in the system.

These systems shall be installed in accordance with all provisions of the National Electric Code and as amended by the details of each individual system (such as type of supports and distance between supports).

Authorities having jurisdiction should be consulted in all cases as to the specific requirements covering the installation and use of these Classified systems.

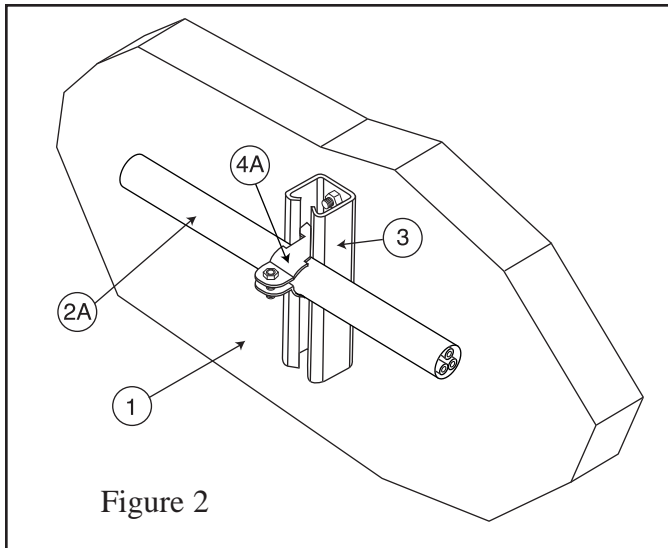

Figure 2

The following instructions are for the VITALink® RHW-2 UL System No. 33, a 2 hour fire rated system. These requirements must be followed to maintain the 2 hour rating in a fire rated area.

- 1. Wall or Floor Assembly** — Minimum 2 hr rated concrete or masonry wall or concrete floor. Through opening in wall or floor shall be firestopped using an approved firestop system. See Through-Penetration Firestop Systems (XHEZ) category for presently Classified firestop systems.
- 2. Conduit**** — Minimum 1/2 in. diameter steel conduit such as, intermediate metal conduit (IMC) or electrical metallic tubing (EMT). May also use UL Listed flexible metallic (must be steel) conduit not to exceed 6 ft. in length.
- 2A. Conduit Coupling**** — (Not Shown) — Threaded steel coupling or electrical metallic tubing fitting-coupling, steel set screw type or steel compression type.
- 2B. Pull Box**** - (Optional Not Shown) – Steel pull box. Cable(s) to be installed with offset.
- 2C. Conduit Body**** - (Optional Not Shown) – Steel conduit body used as a pull point.
- 2D. Pulling Lubricants** – (Optional Not Shown) Polywater “J”, “LZ” or “LZW” may be used with the cables listed in this system. Polywater Dyna Blue, Ideal Yellow 77 with minimum 3/4 in. conduit.
- 3. Fire Resistive Cables*** — Minimum 14 AWG, single conductor Type RHH-RHW-2 cables. Hourly fire rating applies to continuous lengths of cables and coupled conduit (with or without a pull box, conduit body and/or fire rated splice) passing completely through a fire zone and terminating a min of 12 in. beyond the fire rated wall or floor bounding the fire zone.
- 3A. Splice **** – (Optional Not Shown) A taped field splice in a NEMA type 1 enclosure, min. dimensions 8-1/4 by 6-1/4 by 4-1/4 in., to be installed in accordance with manufacturer's installation instructions. The conduit size is to be min. 1/2 in. As an alternate, a terminal block field splice in a NEMA type 1 enclosure, min. dimensions 8-1/4 by 6-1/4 by 4-1/4 in., to be installed in accordance with the manufacturer's installation instructions. The splice may be installed with optional with optional SR tape. The conduit size is to be min. 3/4 in.
- 3B. Ground Wires** – An equipment grounding conductor (where required) shall be installed in each conduit

run. The equipment grounding conductor shall be the same fire rated (RHH/RHW-2) cable listed in this system or a Vitalink Fire Rated ground conductor.

The conduit, couplings and RHH-RHW-2 cable shall be installed in accordance with all provisions of the National Electrical Code.

Due to the increase in leakage current within the cables under fire exposure condition, the use of ground-fault circuit interrupters are not recommended for use with these cables.

RSCC Wire & Cable LLC

VITALink® RHH-RHW-2; VITALink® Ground Wire

4. Supports — Supports on Wall Assemblies — Conduit system(s) can be supported directly on wall assembly (Item 1) using any of the clamps described in Item 5. Support spacing should not exceed 60 in. OC. For conduits supported by steel channel, the channel must be min 14 gauge, by 1-1/2 in. wide or 1-5/8 in. wide, painted or galvanized, slotted steel channels with hemmed flange edges. Channel bottom with or without holes. Lengths of slotted steel channels 5 ft. and less shall be secured to the wall or floor with a min of two 1/4 in. diameter (or larger) by 2-1/4 in. min long concrete screws, or 1/4 in. diameter (or larger) by 1-3/4 in. long min steel masonry anchors. One screw or anchor to be located at each end of the slotted steel channel. Lengths of slotted steel channel in excess of 5 ft. require a min of three screws or anchors, one at each end of the channel and one centrally located within the length of the channel. Supports spaced 60 in. OC.

4A. Supports — In lieu of Item 4. Min 12 gauge, by 1-1/2 or 1-5/8 in. wide, painted or galvanized slotted steel channels with hemmed flange edges. Conduit system(s) can be supported by channel (Item 4) suspended horizontally, trapeze style, by min 3/8 in. diameter threaded steel rods with 1-1/2 in. steel washers and steel nuts. One threaded steel rod to be located at each end of the slotted steel channel. Lengths of slotted steel channel in excess of 5 ft. require a min of three steel rods, one at each end of the channel and one centrally located within the length of the channel. Horizontal, trapeze style, supports should not exceed 60 inches O.C.

4B. Supports – (Optional Not Shown) Conduit system(s) can be supported by one piece conduit hanger (Item 5) suspended by min 1/4 in. diameter threaded steel rods. Threaded rod should be attached to floor assembly or part of the structural steel of the building using a malleable iron beam clamp. Supports not to exceed 60 in. OC.

4C. Vertical Runs – (Optional Not Shown) When installing the RHH/RHW-2 conductors in a vertical raceway the conductors shall be supported. The distance between supports shall be a maximum of 60 feet but not greater than those described in accordance to Table 300.19 of the National Electrical Code (NEC). The supports shall be steel wire mesh type (such as a Kellems Grip) inside a steel box. The raceway shall be supported not more than 72 inches between supports.

5. Clamps — Two hole steel strap (not shown), one piece steel conduit hanger with bolt and nut (such as Minerallac "B" Series - not shown) or two piece 16 gauge min steel single bolt type pipe clamp used with channel described in Item 4 and 4A. Size of clamps to correspond with the outside diameter of the conduit.

*Bearing the UL Classification Mark

**Bearing the UL Listing Mark

Terminating VITALink® RHW-2 at Electrical Switch Gear/Equipment

A junction box is recommended on either end of the fire rated cable in the fire rated room per the following (see Figure 3):

- Once the cable enters the fire rated room, a minimum of 12 inches, terminate or carry through the VITALink® RHW-2 cable into the appropriate size junction box per the NEC Article 314 (see Table 1). Use a UL listed connector, a UL listed lock nut and insulating bushing to terminate the raceway to the box. Connector should be suitably grounded. Equipment grounding conductors should be carried through and maintained as required.
- Using the appropriate raceway for the specified area, connect the junction box to the equipment.
- Install appropriate wiring between the junction box and the equipment.
- Splice VITALink® RHW-2 to the wire using an approved method or carry through. Note a transition splice may be required based on ampacity considerations. (See note 2).
- Seal the end of the raceway in the junction box to keep gases from migrating down into the equipment in the case of a fire. This may be done using a pliable compound.

Note 1: All wiring methods and installation procedures shall comply with the National Electrical Code and local amendments.

Note 2: NEC Article 110-14 should be considered in regard to the temperature limit of the wiring to the equipment. The VITALink® RHW-2 cable may be sized at 90°C if so desired.

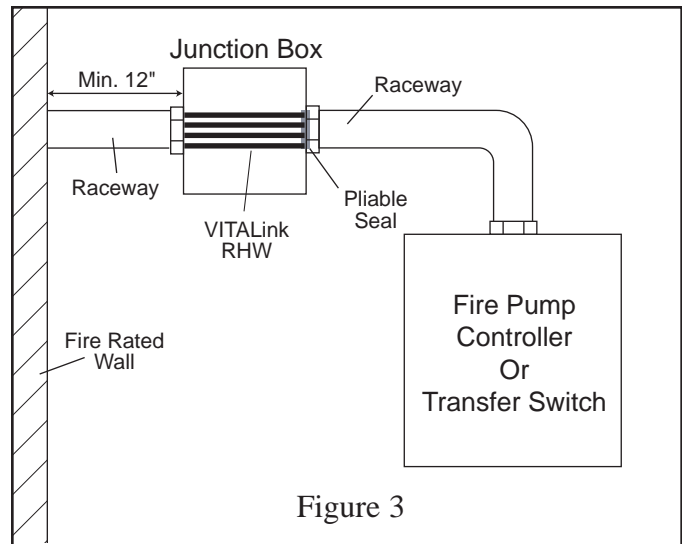

Figure 3

Table 1. Box Size per NEC 314.28

Minimum Box Length for Straight Through Splice					
3-1/C AWG/Kcmil	Conduit Size	Box Size	4-1/C AWG/Kcmil	Conduit Size	Box Size
8	1	8	8	1.25	10
6	1.25	10	6	1.25	10
4	1.25	10	4	1.25	10
3	1.25	10	3	1.5	12
2	1.25	10	2	1.5	12
1	2	16	1	2	16
1/0	2	16	1/0	2	16
2/0	2	16	2/0	2.5	20
3/0	2	16	3/0	2.5	20
4/0	2.5	20	4/0	2.5	20
250	2.5	20	250	3	24
350	3	24	350	3.5	28
500	3	24	500	3.5	28

Minimum Box Size for Angle Splice					
3-1/C AWG/Kcmil	Conduit Size	Box Size	4-1/C AWG/Kcmil	Conduit Size	Box Size
8	1	6	8	1.25	7.5
6	1.25	7.5	6	1.25	7.5
4	1.25	7.5	4	1.25	7.5
3	1.25	7.5	3	1.5	9
2	1.25	7.5	2	1.5	9
1	2	12	1	2	12
1/0	2	12	1/0	2	12
2/0	2	12	2/0	2.5	15
3/0	2	12	3/0	2.5	15
4/0	2.5	15	4/0	2.5	15
250	2.5	15	250	3	18
350	3	18	350	3.5	21
500	3	18	500	3.5	21

All conduit and box sizes in inches.
Based on steel conduit without a ground wire.



A Marmon Wire & Cable / Berkshire Hathaway Company